

GX16 - 600+ AMP 12 to 750 Vdc/Vac

EPIC® Hermetic Sealed DC and AC Contactor

RoHS Compliant, all date codes



Patent Pending

FEATURES

- **Chassis level power terminals** – No need for specially routed power cables, special bus bars, or special lugs.
- **Rugged EPIC® Seal rated to 175°C** – Reduced risk of fire or meltdown in over current conditions. The same technology used for advanced aerospace programs.
- **Hermetically Sealed** – Designed to meet: UL1604 for Class I & II, Div 2 and Class III for use in hazardous locations, IP67 for temporary water immersion for 30 min, SAE J1171 - external ignition protection, and ISO8846 for protection against ignition around flammable gasses.
- **High Efficiency Dual DC Coils** – Very low 12 or 24 VDC continuous coil power with no EMI emissions or cross-talk on your system control power. Ideal for battery powered systems or where low power is needed.
- **Built-in coil suppression for all DC coils** – Saves you engineering time and parts cost to add external coil suppression.
- **Stainless steel hardware and mounting inserts**, for years of corrosion free service.
- **Not position sensitive** – can be mounted in any position for ease of installation

POWER SWITCHING & CURRENT CARRY RATINGS

Current	Life Ratings for Given Contact Voltages					Temp Rise vs Conductors (°C)		
	24VDC	120VDC	240VAC	300VDC	700VDC	300MCM	400MCM	900MCM
600A	100,000	4,000	TBD	2,000	500	100	75	60
400A	200,000	10,000	TBD	5,000	1,000	75	55	40
200A	300,000	20,000	TBD	10,000	2,000	50	25	15
100A	300,000	40,000	TBD	20,000	4,000	15	10	5
50A	300,000	100,000	TBD	50,000	8,000	6	4	2
Max Make (2X)	1,500	1,000	1,000	1,000	600	N/A	N/A	N/A
Max Break (2X)	5,000	3,000	TBD	2,500	1,000	N/A	N/A	N/A

Electrical life rating is based on resistive load with 27µH maximum inductance in circuit. Because your application may be different, we suggest you test the contactor in your circuit to verify life is as required.

End of life is defined as when the dielectric, insulation resistance or contact resistance exceeds the specifications listed.

PRODUCT SPECIFICATIONS

Specifications	Units	Specifications
Contact Arrangement (main)	Form X	SPST-NO
Contact Arrangement (Auxiliary) 1/	Form A	SPST-NO
Mechanical Life	cycles	300,000
Contact Resistance		
Max @ rated carry current	mohms	.3
Typical @ rated carry current	mohms	.11 to .2
Operate time, 25°C		
Close (includes bounce) Max	ms	20
Close (includes bounce) Typical	ms	13
Bounce on close, Max	ms	7
Release time (includes arc time at max. break current)	ms	7
Insulation Resistance	Mohms	100 2/
Dielectric at sea level (leakage < 1mA)	VRMS	2,000
Shock	G's peak	20
Vibration, Sinusoidal (500-2000 Hz peak)	G's	15
Operating ambient Temp Range	°C	-55 to +85 3/
Storage ambient Temp Range	°C	-70 to +175
Weight, Typical	Kg (Lb)	0.9 (1.9)

COIL RATINGS		
Coil Voltage (Nominal)	12Vdc	24Vdc
Coil P/N Designation	B	C
Coil Voltage (Max) 4/	16	33
In-Rush Current Max (75 ms) – Amps 5/ 6/	3.45	1.79
Coil Current after in-rush (Avg.) - Amps 6/	0.61	0.31
Coil Power after in-rush (Avg.) – Watts 6/	7.8	8
Pick-up, Volts, Max 5/ 7/ 8/	7.5	15.0
Hold, Volts, Min 8/	5.0	10.0
Drop-Out, Volts, Min 8/	1.0	2.0
Coil Back EMF (volts) 9/	45	45

PART NUMBER SYSTEM		
GX16		B E B
Coil Voltage B = 12 Vdc, internal coil suppression C = 24 Vdc, internal coil suppression		
Coil Termination E = 8 Pin Deutch Connector		
Auxiliary Contact Blank = None B = SPST, Normally Open		

MOUNTING

M6 OR NO. 12 SCREWS
TORQUE 1.7-4Nm [15-35in-lb]

CASE MATERIAL

DUPONT ZYTEL FR50 (30%
GLASS FILLED NYLON)

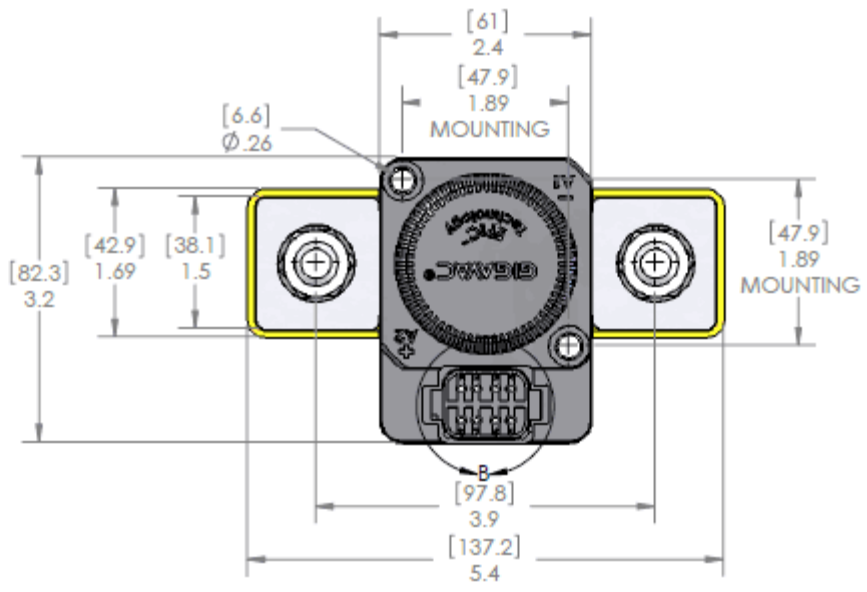
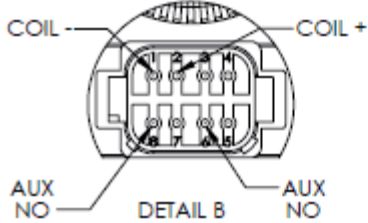

POWER CONNECTION

ZINC PLATED, GRADE 8, 1/2-13 BOLT*
STAINLESS 1/2-13 NUT*
STAINLESS LOCK WASHER
STAINLESS FLAT WASHER

TORQUE 200-300 IN-LB

*ON JULY 1, 2010 HARDWARE CHANGES
TO M12X1.75

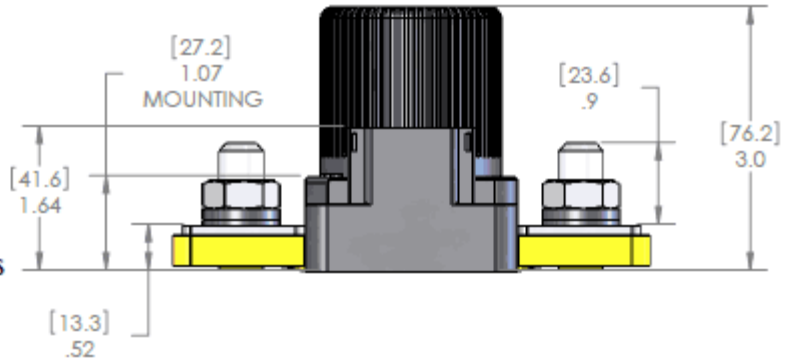

MATING CONNECTOR

DEUTSCH CONNECTOR HOUSING P/N: DT06-08S
SOLID CONTACT SOCKET P/N: 062-201-16141
WEDGE LOCK P/N: W8S
SEALING PLUG P/N: 114017
CRIMP TOOL P/N: HDT-48-00

Power contacts

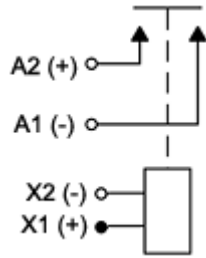

Auxiliary contacts (optional)

Normally Open (T2 to T1) is available.

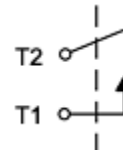

Application Information:

1. WARNING - When using more than one lug on a power terminal, make sure the primary power is closest to the contactor busbar, with the lower current lug on top, then the washer, then the lock washer, then the nut. **Improper order can cause severe over-heating resulting in the possible melting of the connecting cable insulation.**

2. [EPIC®](#) sealing technology

3. [Relay Schematics and Forms](#)

Notes & Definitions:

1/ Auxillary contact rating - 2A, 24Vdc Resistive load, 100,000 cycles. Minimum current is 100mA, 8V. The auxiliary contact is mechanically linked to the main power contacts.

2/ 50 Mohms after life.

3/ Contactor can operate up to 125°C in special cases - contact GIGAVAC for details.

4/ Because the contactor is operated by a coil that changes resistance with temperature, the maximum coil voltage will be lower than indicated at temperatures above 25C, and higher than indicated at temperatures below 25C.

5/ Contactor has two coils. Both are used for pull-in, and then in approximately 75 milliseconds, one coil is electronically removed from the coil drive circuit. The remaining coil supplies low continuous hold power sufficient for the contactor to meet all of its specified performance specifications. This provides the lowest coil power possible without the use of PWM electronics that have been known to cause EMI emissions and/or cross-talk on your system control power.

6/ Because the contactor is operated by a coil that changes resistance with temperature, and because Nominal Coil voltage has been assumed for the In-Rush, Hold Current and Hold Power specifications, Current/Wattage will be lower than indicated at temperatures above 25C and higher than indicated at temperatures below 25C.

7/ For Pick-up testing of contactors with dual coils, the voltage can not be ramped up slowly, but must be applied instantly to at least the maximum pull-in voltage or current. Otherwise, the contactor will not pick-up.

8/ Because the contactor is operated by a coil that changes resistance with temperature, Pick-up Voltage, Hold Voltage, and Drop Out Voltage will be lower than indicated at temperatures below 25C and higher than indicated at temperatures above 25C.

9/ These DC coils have built-in coil suppression. The use of additional external coil suppression can slow the release time and invalidate the life cycle ratings, or can cause the contactor not to be able to interrupt the maximum current specified. If lower coil back EMF is required, please [contact GIGAVAC](#) for assistance.

03/08/10



GIGAVAC® - P.O. Box 4428 - Santa Barbara, CA 93140-4428 - ph +(805) 684-8401 - +(805) 755-2000
fx +(805) 684-8402 - - www.gigavac.com - ©Copyright 2003-2010 GIGAVAC, LLC.