

## Latching SPST EPIC® Sealed Contactor - 350+ Amp Power Switching

RoHS Compliant, all date codes



Patent Pending

FEATURES	
•	<b>Latching version of GIGAVAC GX14.</b>
•	<b>Chassis level UL508 sized power terminals</b> – No need for specially routed power cables, special bus bars, or special lugs.
•	<b>Rugged EPIC® Seal rated to 175°C</b> – Reduced risk of fire or meltdown in over current conditions. The same technology used for advanced aerospace programs.
•	<b>Hermetically Sealed</b> – Designed to meet: UL1604 for Class I & II, Div 2 and Class III for use in hazardous locations, IP67 for temporary water immersion for 30 min, SAE J1171 - external ignition protection, and ISO8846 for protection against ignition around flammable gasses.
•	<b>High Efficiency Coils</b> – Very low pull-in coil power and no hold power.
•	<b>Built-in coil suppression</b> – Saves you engineering time and parts cost to add external coil suppression.
•	<b>Stainless steel hardware and mounting inserts</b> , for years of corrosion free service.
•	<b>UL508 ambient compliant to 75°C</b> but can operate continuously at 85° C with a higher terminal temperature rise of 60°C. Can also operate up to 125°C in special cases - contact GIGAVAC for details.
•	<b>Not position sensitive</b> – can be mounted in any position for ease of installation

POWER SWITCHING & CURRENT CARRY RATINGS								
Current	Life Ratings for Given Contact Voltages					Temp Rise vs Conductors (°C)		
	24VDC	120VDC	240VAC	300VDC	700VDC	2/0	3/0	4/0
<b>350A</b>	100,000	4,000	TBD	2,000	500	75	60	50
<b>225A</b>	200,000	10,000	TBD	5,000	1,000	55	45	35
<b>150A</b>	300,000	20,000	TBD	10,000	2,000	40	20	12
<b>100A</b>	300,000	40,000	TBD	20,000	4,000	12	8	4
<b>50A</b>	300,000	100,000	TBD	50,000	8,000	5	3	2

Electrical life rating is based on resistive load with 27µH maximum inductance in circuit. Because your application may be different, we suggest you test the contactor in your circuit to verify life is as required.

End of life is defined as when the dielectric, insulation resistance or contact resistance exceeds the specifications listed.

At 85°C ambient, contactor can also meet all of its 75°C specifications but the terminal temperature can rise can be up to 60°C, which is higher than the 50°C rise allowed by UL508 and can be higher than some cable insulation ratings.

UL COMPLIANT DC & AC CONTACT CURRENT CARRY RATINGS		
		75°C / 50°C
<b>Cable size 1/</b>	KCmil	400
<b>Continuous, UL508 Max 1/</b>	<b>Amp</b>	<b>350 / 400</b>
10 seconds (1 time)	Amp	525 / 710
100 Seconds (1 time)	Amp	390 / 510
300 Seconds (1 time)	Amp	350 / 400
<b>Maximum terminal Temp, Continuous</b>	Deg C	175
<b>Maximum terminal Temp, Intermittent</b>	Deg C	200

**1/** Assumes UL508 ratings with 400 KCmil cables, ambient max. UL508 temperature of 75°C, and max. UL508 terminal temperature rise of 50°C. Contactor can also carry the higher currents shown at 50°C ambient, and meet all of the UL508 requirements.

Contactors meet all of its published specifications at 85°C ambient, but terminal temperature can rise 60°C, which is higher than the 50°C allowed by UL508.

The maximum terminal temperature rating is 175°C, which means much higher currents can be carried and switched. However, this temperature is much higher than most cable insulation ratings, which mean busbars must be used. Contact GIGAVAC for assistance for higher current applications.

COIL RATINGS		
Coil Voltage (Nominal)	12Vdc	24Vdc
Coil P/N Designation	B	C
Coil Voltage (Max) 1/	15	30
Operate & Reset Pick-up, Current, Max - Amps 2/ 3/	4.0	1.7
Operate & Reset Pick-up, Volts, Max 2/ 3/	7.5	15.0
Coil Back EMF (volts) 4/	45	45

Ratings are at 25°C. For specific values at other temperatures, please [contact GIGAVAC](#).

**1/** Because the contactor is operated by a coil that changes resistance with temperature, the maximum coil voltage will be lower than indicated at temperatures above 25C, and higher than indicated at temperatures below 25C.

**2/** Minimum pulse of 100ms required. Coil pulse limited to <100ms by internal electronics.

**3/** Because the contactor is operated by a coil that changes resistance with temperature, Pick-up Voltage, Hold Voltage, and Drop Out Voltage will be lower than indicated at temperatures below 25C and higher than indicated at temperatures above 25C.

**4/** These DC coils have built-in coil suppression.

PRODUCT SPECIFICATIONS		
Specifications	Units	Specifications
Contact Arrangement (main)	Form P	SPST (latching)
Contact Arrangement (Auxiliary) <b>1/</b>	Form A	SPST (NO)
Mechanical Life	cycles	1 million
<b>Contact Resistance</b> Max @ rated carry current Typical @ rated carry current	mohms mohms	.4 .15 to .3
<b>Operate time, 25°C</b> Close (includes bounce) Max Close (includes bounce) Typical Make Bounce on close, Max Break time (includes arc time at max. break current)	ms ms ms ms	20 13 7 12
<b>Insulation Resistance</b>	Mohms	100 <b>2/</b>
<b>Dielectric at sea level (leakage &lt; 1mA)</b>	VRMS	2,000
<b>Shock</b>	G's peak	10
<b>Vibration, Sinusoidal (500-2000 Hz peak)</b>	G's	10
<b>Operating ambient Temp Range</b>	°C	-55 to +85 <b>3/</b>
<b>Storage ambient Temp Range</b>	°C	-70 to +175
<b>Weight, Typical</b>	Kg (Lb)	0.50/(1.1)

**1/** Auxillary contact rating - 2A, 24Vdc Resistive load, 100,000 cycles. Minimum current is 100mA, 8V. The auxiliary contact is mechanically linked to the main power contacts.

**2/** 50 Mohms after life.

**3/** Contactor can operate up to 125°C in special cases - contact GIGAVAC for details.

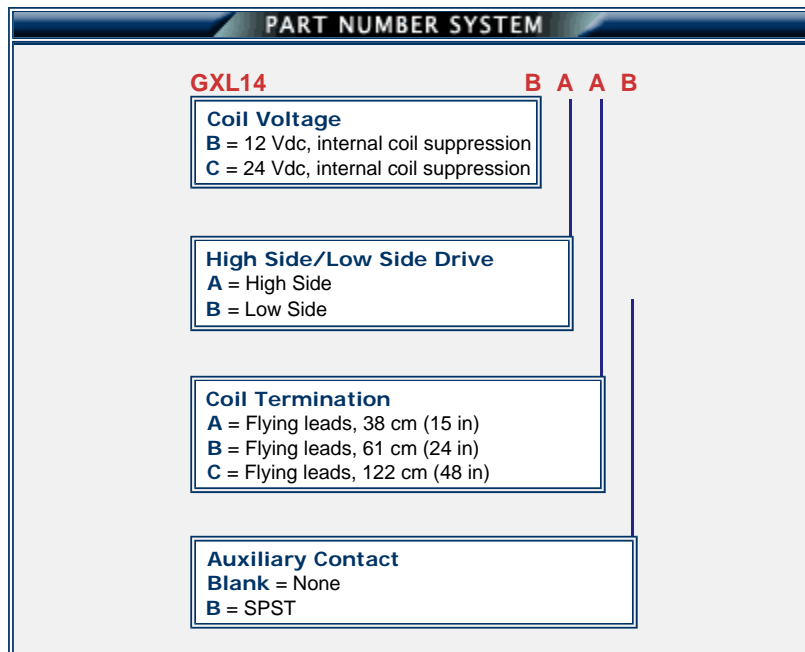

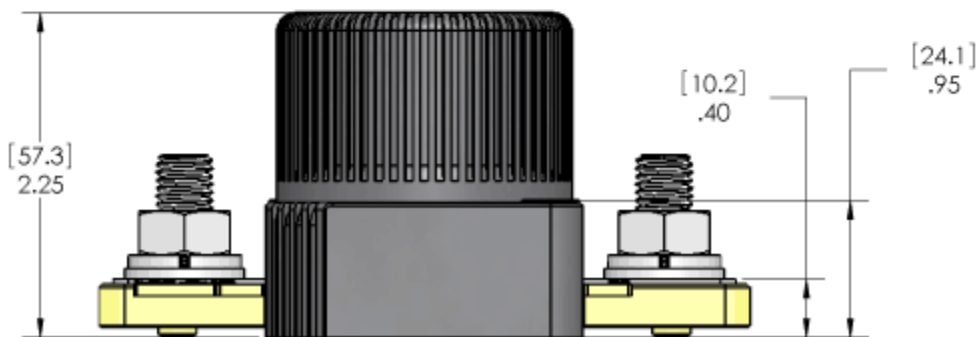
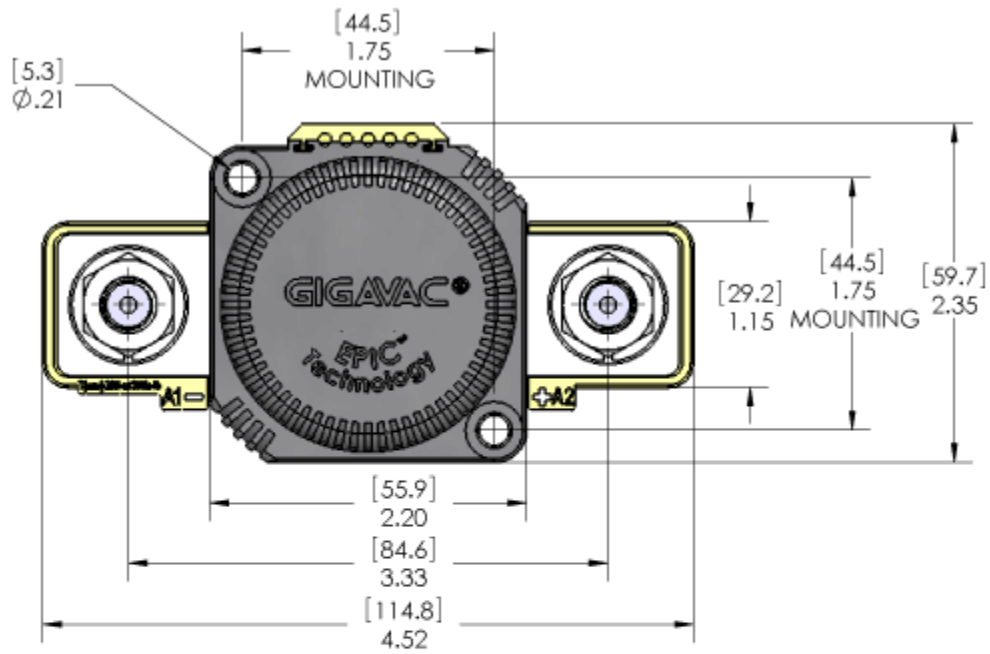

**MOUNTING**

M5 OR NO. 10 SCREWS  
TORQUE 1.7-4Nm [15-35in-lb]

**CASE MATERIAL**

DUPONT ZYTEL FR50 (30%  
GLASS FILLED NYLON)

**POWER CONNECTION**

ZINC PLATED, M10X1.5 BOLT  
STAINLESS M10X1.5 NUT  
STAINLESS LOCK WASHER  
STAINLESS FLAT WASHER

TORQUE 100-200 IN-LB

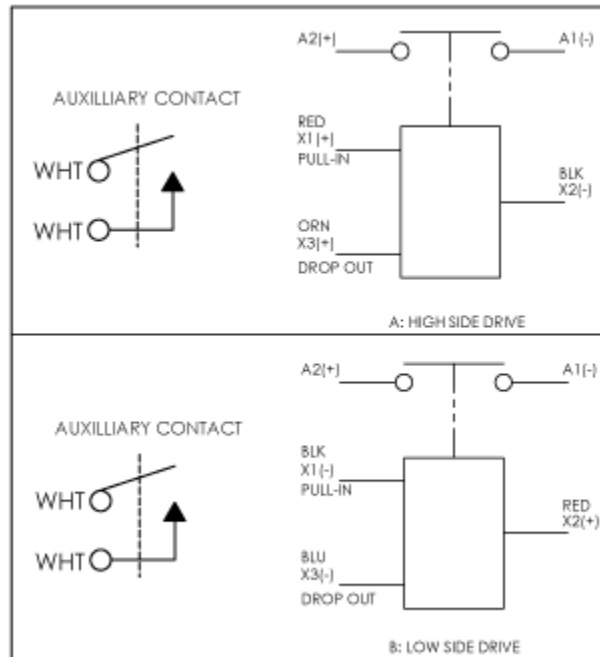

## Application Information:

1. **WARNING** - When using more than one lug on a power terminal, make sure the primary power is closest to the contactor busbar, with the lower current lug on top, then the washer, then the lock washer, then the nut. **Improper order can cause severe over-heating resulting in the possible melting of the connecting cable insulation.**

2. EPIC® sealing technology

3. Relay Schematics and Forms

04/14/10



GIGAVAC® - P.O. Box 4428 - Santa Barbara, CA 93140-4428 - ph +(805) 684-8401 - +(805) 755-2000  
fx +(805) 684-8402 - [info@gigavac.com](mailto:info@gigavac.com) - [www.gigavac.com](http://www.gigavac.com) - ©Copyright 2003-2010 GIGAVAC, LLC.